

STRAIGHT 2 HOLES FLANGE FLOATING JACK
SOLDER TYPE FOR CABLE .085

R128.292.727

Series : BMA-COM

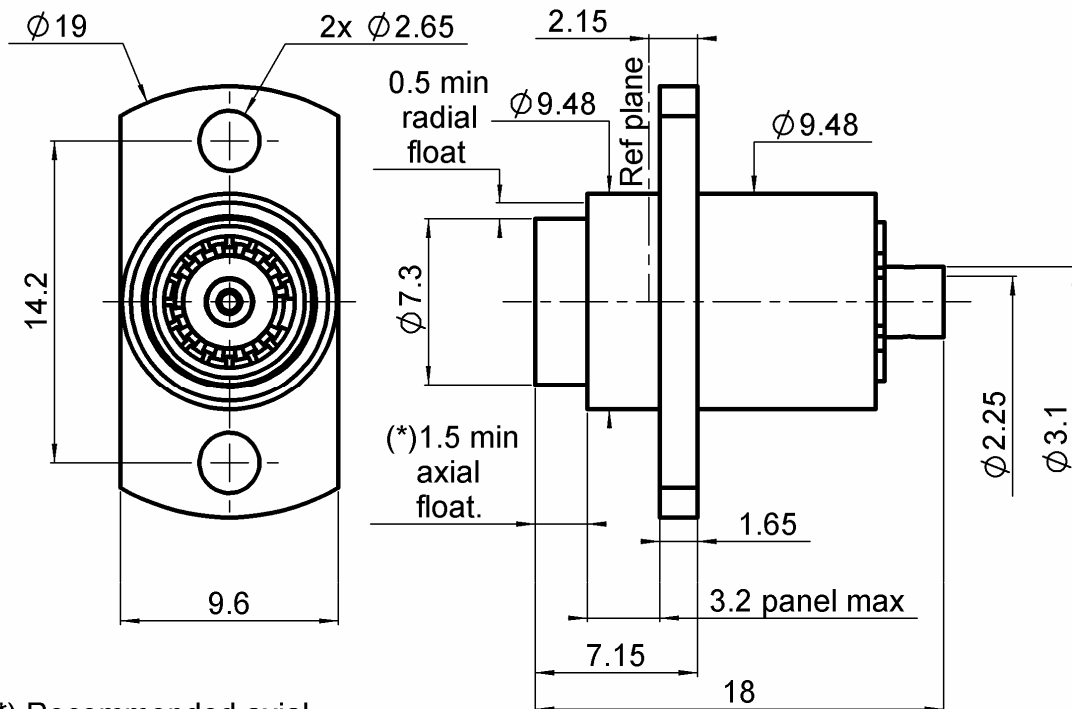

(*) Recommended axial float mount for best electrical performance: 0.51 +/- 0.25 mm (.020" +/- .010)

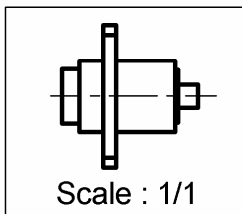

PANEL DRILLING

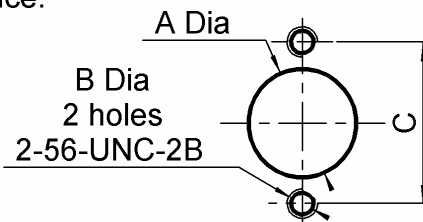

	maxi	mini
A	9.6	9.55
C	14.3	14.1

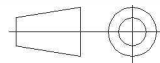
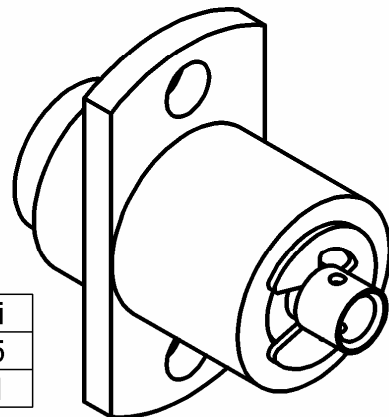

All dimensions are in mm.

COMPONENTS	MATERIALS	PLATING (µm)
BODY	BRASS	BBR2
CENTER CONTACT	BERYLLIUM COPPER	NPGR
OUTER CONTACT	BERYLLIUM COPPER	NPGR
INSULATOR	PTFE	
GASKET	-	
OTHERS PARTS	BRASS	BBR2
-	-	-
-	-	-

Issue : 0941 B

In the effort to improve our products, we reserve the right to make changes judged to be necessary.



STRAIGHT 2 HOLES FLANGE FLOATING JACK
SOLDER TYPE FOR CABLE .085

R128.292.727

Series : **BMA-COM**

PACKAGING

Standard	Unit	Other
100	'W' option	Contact us

SPECIFICATION

ELECTRICAL CHARACTERISTICS

Impedance		50	Ω
Frequency		0-22	GHz
VSWR	1.05 +	0,0100	x F(GHz) Maxi
Insertion loss		0.03	\sqrt{F} (GHz) dB Maxi
RF leakage	- (90	- F(GHz)) dB Maxi
Voltage rating		350	Veff Maxi
Dielectric withstanding voltage		1000	Veff mini
Insulation resistance		5000	M Ω mini

CABLE ASSEMBLY

Stripping	a	b	c	d	e	f
mm	1,78	0,00	0,00	0,00	0,00	0,00

Assembly instruction :

Recommended cable(s)
 KS 1
 RG 405

MECHANICAL CHARACTERISTICS

Center contact retention			
Axial force – Mating end		18	N mini
Axial force – Opposite end		18	N mini
Torque		NA	N.cm mini

Characteristics indicated on this data sheet are those that can be achieved with the highest performance cable. Intrinsic limitations of the cable may diminish the performance of the assembly

Cable retention

- pull off		136	N mini
- torque		NA	N.cm

TOOLING

Recommended torque			
Mating			N.cm
Panel nut		NA	N.cm
Clamp nut		NA	N.cm
A/F clamp nut		0,0000	mm
Mating life		1000	Cycles mini
Weight		3,3000	g

Part Number	Description	Hexagon
.	.	.
R282.740.000	SOLDERING MOUNTING	
R282.051.000	STRIPPING TOOL	
R282.062.000	POINTER GAUGE	
R282.860.130	SOLDER POSITIONER BMA	

ENVIRONMENTAL

Operating temperature		-40/+105	$^{\circ}$ C
Hermetic seal		NA	Atm.cm3/s
Panel leakage		*IP54	

OTHER CHARACTERISTICS

*Mated with waterproof male connector

It is recommended to use a service loop to facilitate the float features of the connector

Issue : **0941** **B**

In the effort to improve our products, we reserve the right to make changes judged to be necessary.



STRAIGHT 2 HOLES FLANGE FLOATING JACK
SOLDER TYPE FOR CABLE .085

R128.292.727

Series : BMA-COM

COMPONENT

STRIPPING DIMENSION

BODY

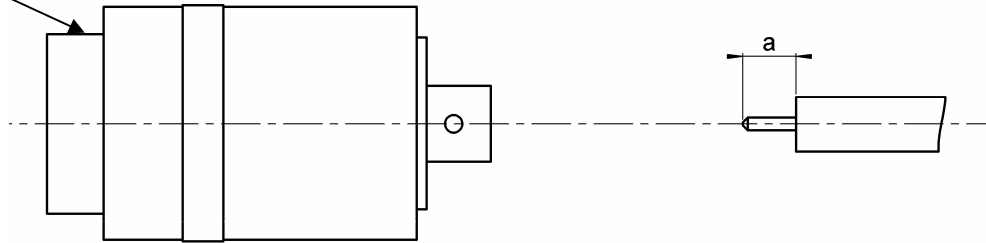

We recommend a cable thermal preconditioning before assembly

1

- Strip the cable with the cable stripping tool.
- Trim the cable inner conductor with the trimmer.
- Clean the cable

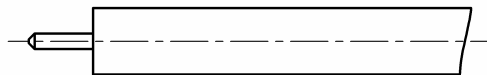

2

- Introduce the cable into the body until contact with the body shoulder..
- Place the sub-assembly on assembly jig with the positioner and tighten it.
- Solder body on the cable.
- Let assembly cool down before removing it from the jig.
- Cleaning the solder area.

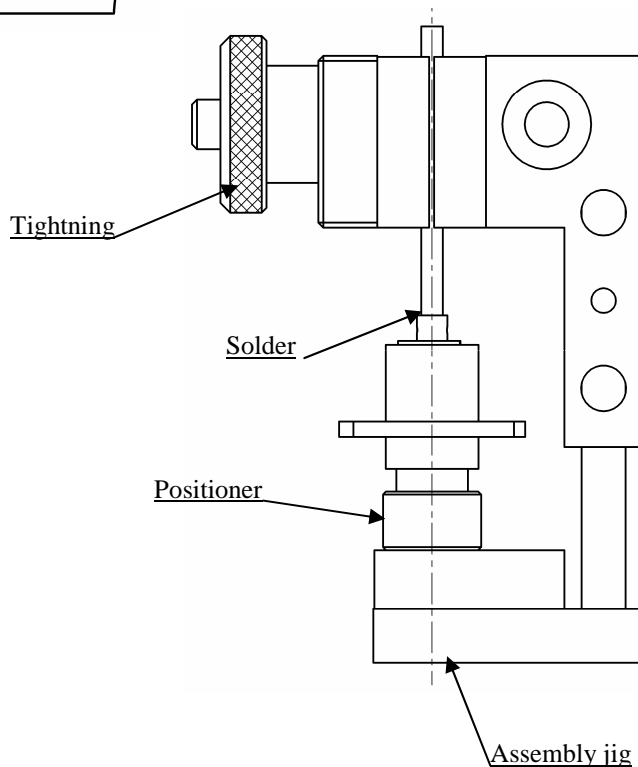

Issue : 0941 B

In the effort to improve our products, we reserve the right to make changes judged to be necessary.

